

**Motor Stick:**  
 Tube: 0.009", 4.6 #, C, 0.1875" ID  
 Bracing Post: 0.040" OD => 0.025" OD  
 Bracing Wire: 0.001" Tungsten  
 Thrust Bearing: Modified Harlan 10mg  
 Rear Hook: 0.010" Music Wire  
 Wing Posts: 0.045" OD, 5.8#  
 Stub Boom: 0.009", 4.0#, 0.01875" ID

**Boom:**  
 Boom: 0.007", 4.1#, C, Harlan Form  
 Stab Posts: 0.045" OD, 5.5#

**Wing:**  
 Spars: 0.040" x .031" => 0.035" x 0.031", A, 5.0#  
 Tips: 0.030" x 0.027", A, 4.7#  
 Ribs: 0.020" x 0.040", C, 4.2#

**Stab:**  
 Spars: 0.030" x 0.023" => 0.025" x 0.023", A, 5.15#  
 Tips: 0.025" x 0.023", A, 5.15#  
 Ribs: 0.020" x 0.030", C, 4.2#

**Prop:**  
 Outline: 0.019" x 0.019", A, 5.0#  
 Ribs: 0.017" x 0.020", C, 4.3#  
 Spars: 0.045" x 0.047" => 0.025" x 0.020", C, 5#  
 Formed Pitch: 17.6" (Helical)  
 Diameter: 12"  
 VP Treger (low 14", high 24")

**Covering:**  
 All Surfaces Y2K2

**Weights:**  
 Motor Stick: 118mg  
 Boom: 46mg  
 Wing: 92mg  
 Stab: 50mg  
 Prop: 98mg  
 Total: 404mg

**Record Flight:**  
 Time: 33:42  
 Motor: 15.5" Loop, 552mg, 5/99, 3750 Turns  
 Location: Hanger 1, Lakehurst, NJ

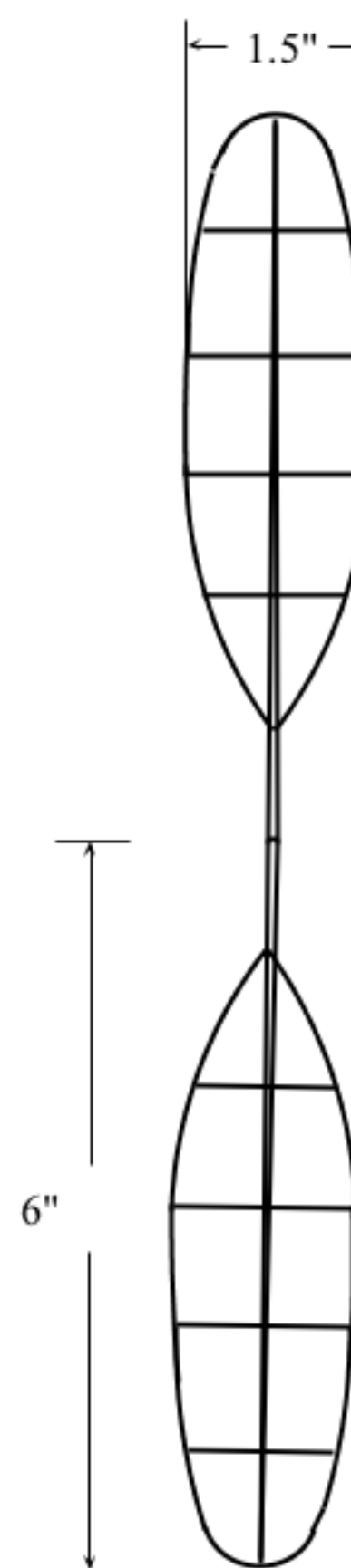
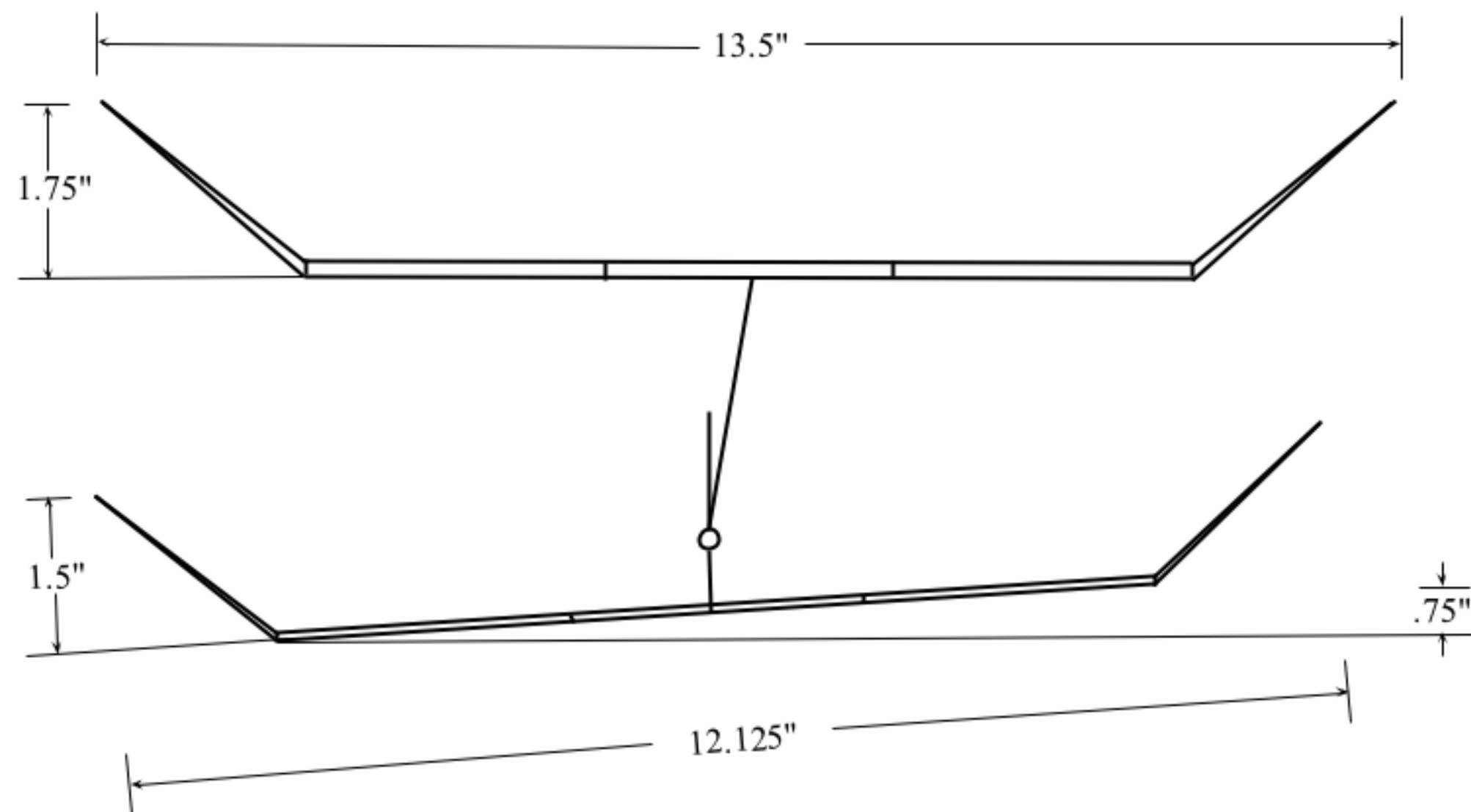
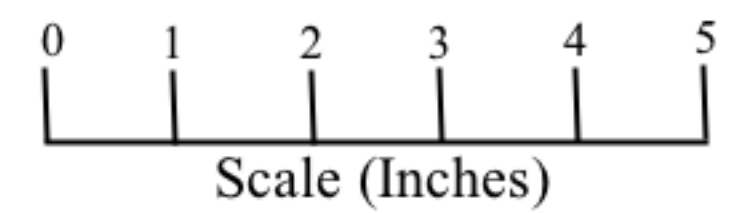
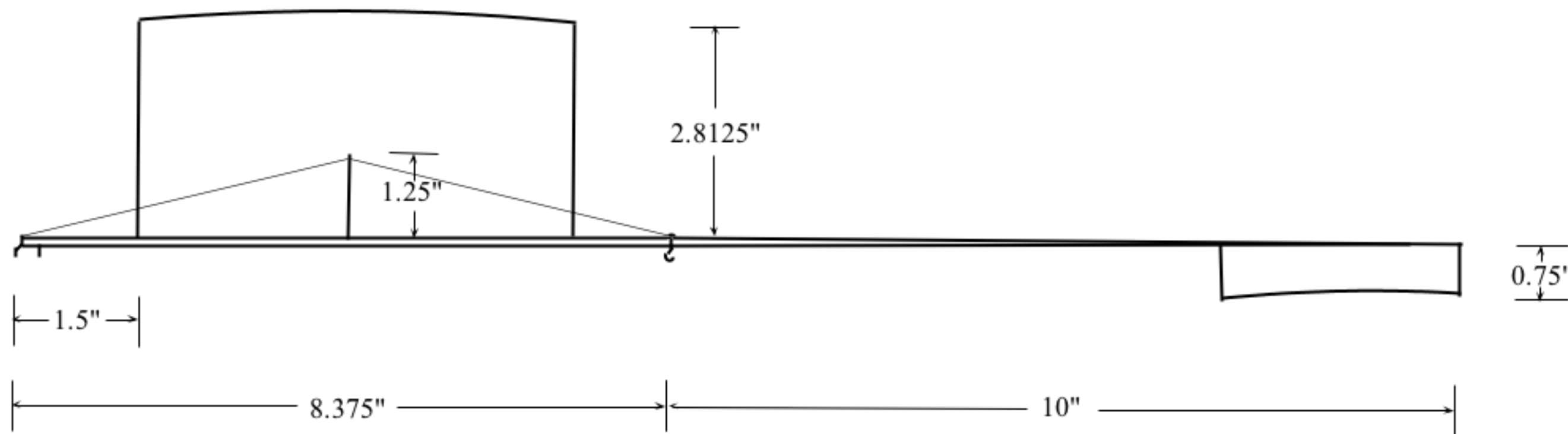

**F1R**  
 AMA Cat IV National Record  
 By  
 Nick Ray