

# INDOOR

## NEWS and VIEWS

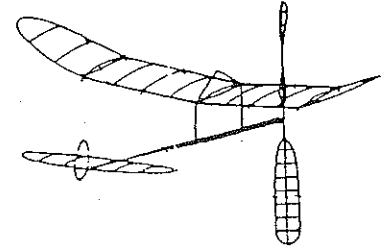

### FROM THE EDITOR'S DESK

Greetings,

Welcome back to the Indoor News and Views. After about a year and a half of no issues of the newsletter, I, as well as others felt we needed this means of communications. So with pen in hand, I have taken the job of your new editor. The format of the newsletter will change as will the issuance of the newsletter. At present the plan is 10 pages of information of indoor information and 6 copies a year. This will give us more up to date information as well as new techniques, results of recent contest and any rules changes or proposals.

Now a little about your new editor. First off, I am not an English major, I was a Sergeant Major. I am not a computer whiz, some have identified me as a Ludite. The Brainbuster Newsletter was my baby for 29 consecutive years, so I do know a little bit. I also have a burning desire to get information out to our indoor modelers. I have a collection of Bud Tenny's Indoor News and Views, some of them were just two pages, but Bud got the important stuff out to us.

As your editor, your help is needed to get information to me so that it is passed on to our indoor brothers and sisters. There is a possibility that all of it will not get passed on as there may be more important matters to get out ASAP, (As soon as possible). I will try to inform you of this by E-mail or regular mail. Some subscribers will notice that this issue is their last issue. In the past you were promised 4 issues and this will be their fourth, hence these subscribers will need to renew or to drop out. At present we have about 280 subscribers with 51 of them, overseas participants. We hope it stays at this or improves. It's up to you and I. My E-mail address is [vandover@cox.net](mailto:vandover@cox.net) and we hope to hear from you. Positive or negative.

PS The 2011 AMA/NFFS Indoor Nationals will be in Johnson City, TN on the 1-5 of June 2011 This is tentative. Plan ahead!

## Indoor Model Specialties

### High quality, Low prices

Tools from Scales to Rubber Strippers  
Material from Ultrafilm to Thrust Bearings  
Bambino competitive Science Olympiad model kit

See my brochure under Links at  
<http://www.indoorduration.com>

Ray Harlan  
15 Happy Hollow Road  
Wayland, MA 01778  
508.358.4013

Mastercard and Visa accepted

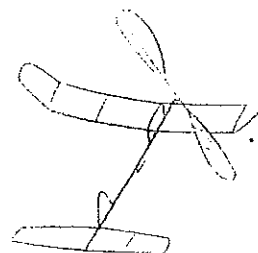

Once again die hard indoor modelers flocked to Johnson City, TN for the annual National Indoor Championships. There were more than in 2009 and we hope the trend improves. You can be sure this newsletter will keep you informed in 2011 about what's happening at the National level. Back to the 2010 event. We have both pictures and results and a little bit of who did what. John Kagan will give you a more polished version in an upcoming Model Aviation. I'm sure Don DeLoach of NFFS Digest will also have some info on this National event. We cannot get all of this years events in one edition, so that will be in later issues, we will also have all those that flew in each event, no matter how lousy I was. We flew and that's what matters. I told you I was not an English major didn't I ?

Two Site records were set, one by Stan Buddenbohm and the other by a Junior, the name escapes me, but we will have it in the August/ September issue. A big letdown was that the Smyrna group only had five Juniors. This was due to a fire at their Church. Tim Lavender did have at least 6 Open Contestants to pick up the slack. Tim is the leader of the group and the Church Pastor. Now there is a story for another issue.

All the photos are by Ken Achee, except the one of him, he's not that fast, but he did get around. Ken brought a friend with him, Paul Grabski by name. Paul won Peanut Scale and this was his first Nationals.

For all you Tony Italiano fans he was absent for the first time in over 20 years. If you can remember back that far, Tony started all this stuff at Johnson City and ran the event for at least 10 years. Tony told me by telephone the he was OK, however his driver, Jack Boone could not make it, hence , no Tony. Next year for sure. Below and on other pages are the scores and pictures. All the captions are by me.

---

### BIG THANK YOU TO THE HIRED HELP.

First of all no one was hired and all the help was by volunteers, Think about it !! Carl Bakay was the overall Event Director, J. P. Kish was the scorer all five days. Dave Thomson handled the processing and set up all the measuring devices, plus did the Scale judging chores. Phil Sullivan represented the AMA and filled in as needed Phil is also the NFFS President. John Kagan helped with computer repair and ran the Pro-Am Limited Pennyplane Event which, by the way was a big hit. Maybe, we can get John to write up something for us in the next issue. A big thank you goes to Tim Goldstien for donating a ton of kits and stuff for the big raffle that by the way earned almost a thousand bucks that goes to the AMA to offset the rental of the site. Tim also donated kits for the Pro-Am event.

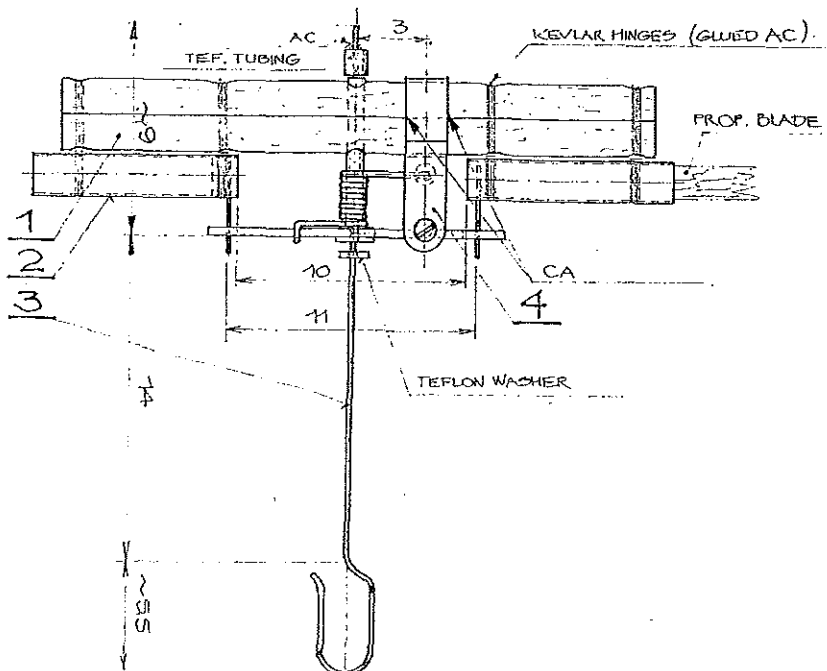

### VARIABLE PITCH PROP.

To your left is a line drawing of a variable pitch prop. If this wets your interest, you will have to wait until the next issue comes out in September. We will then have a complete run-down on it. This will make the wait worth it. Trust me

# MAKE INVISIBLE REPAIRS TO MODEL PARTS

Larry Coslick

I use this repair method for just about any repair job on an indoor model and it makes the lightest and neatest repair. I use thinned down carpenters glue (Aliphatic) with saliva and a small 10/0 artists brush. Place a small dab of glue on a piece of masking tape and mix it with the same amount of saliva. Light stab outlines break easily and if the film is holding the break together, place the thinned glue on the face and bottom of the outline. The mixture is very thin and will soak into the balsa easily even though you may not be able to open the break. If the stab has folded and the film is intact, carefully place the folded part back to its original position. Take the smallest amount of glue and place it between the break and align the two ends. Do one break at a time. There's no need to pre glue and it will only take about 10 minutes for the glue to dry at 70 degree F. Another advantage is that the break can be manipulated after it sets for around 4 minutes. I try to keep the glue away from the inside of the outline to keep from getting the glue on the film. If glue gets on the film use a clean damp brush to remove the glue. I don't use Aliphatic on areas that are laced with Boron.

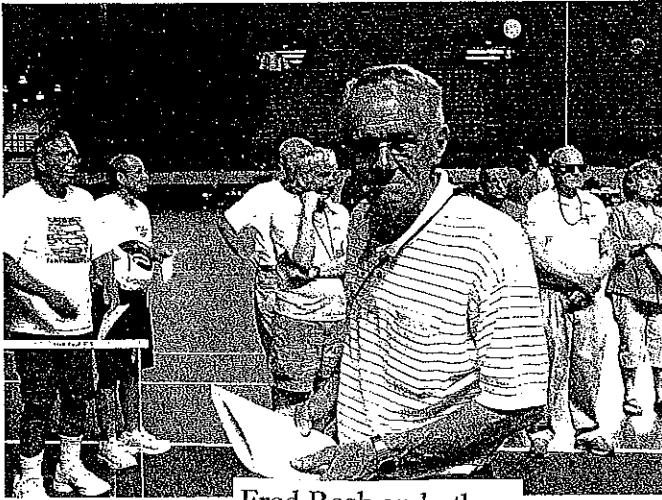

Fred Rash and others

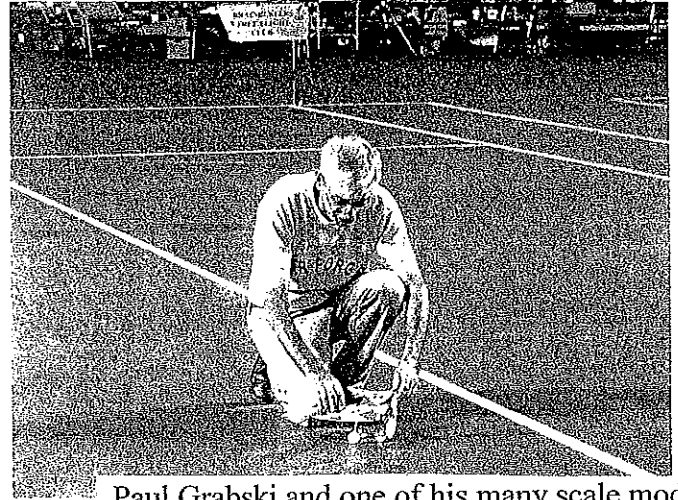

Paul Grabski and one of his many scale models

INAV Subscriptions are for a 1 year period, during which 6 issues of 10 pages are anticipated. This mode will start with issue # 124. USA subscriptions are mailed First Class, all others are Airmail.

## Adult Subscriptions

USA	US \$15.00/ year
Canada	US \$ 19.00/year
All Others	US \$ 24.00/year

At this time there is no Junior Subscription. This may change in the near future as we settle our finances.

Send all subscriptions To:

Abram Van Dover  
112 Tillerson Dr  
Newport News, VA  
23602-4011  
[vandover@cox.net](mailto:vandover@cox.net)

Co-Editors- Carl Bakay, Jeff Hood.  
Contributing Editor- Nick Aikman, UK  
Contributing Editor-Bill Gowen

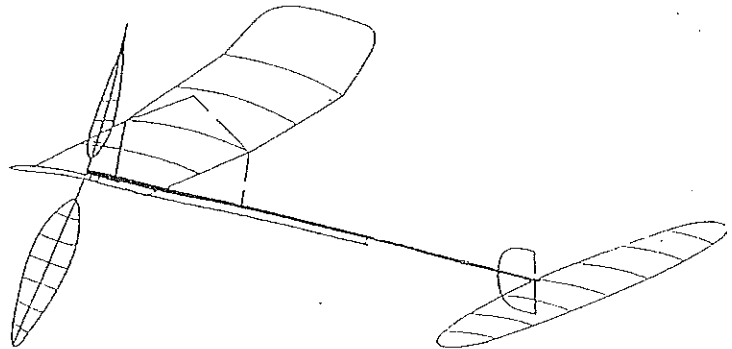

Indoor News and Views is an open forum presenting ideas, opinions, model designs and techniques for the indoor community. Unless specifically stated INAV does not offer any opinion as to the merit of published work, nor does it indorse any products or services advertised herein. 3

Bostonian

Name	AMA #	Flight 1	Flight 2	Flight 3	Flight 4	Flight 5	Best	2nd Best	Flt Total	Charisma	Total	Place
EMIL SCHUTZEL	508384	4:12	4:41	4:29			4:41	4:29	9:10	1.20	11:00	1
FRED RASH	63458	3:53	4:10				4:10	3:53	8:03	1.15	9:15	2
H DIEBOLT	5286	3:31	4:13	1:24	3:14		4:13	3:31	7:44	1.15	8:54	3
SORIN SLATER (JR)	880359	0:31	0:48	0:52	0:47	0:41	0:52	0:48	1:40	1.10	1:50	4
LOU YOUNG	3304	1:37					1:37		1:37	1.10	1:47	5
ROBERT WARMANN	187	0:08					0:08		0:08	1.10	0:09	6
ROBERT BOYD	44454	0:42	0:21	0:45	3:14		3:14	0:45	3:59		0:00	7
RAYMOND HARLAN	131										DNF	
ROBERT STEVENS	615257										DNF	

FAC Scale

Name	AMA #	Aircraft	Const. Det.	Color & Markings	Work.	Scale Score	Bonus Points	1st Flight	2nd Flight	3rd Flight	Flight Points	Total Points	Place
ROBERT STEVENS	615257	1911 Voisin	25	20	12.5	57.5	30	46	49	44	49.00	136.50	1
KATIE BOSMAN	336184	Douglas SBD	28	20	11.0	59.0	10	39			39.00	108.00	2
VAL THOMAS	944976	Piper Vagabond	30	20	12.5	62.5	0	38	41	35	41.00	103.50	3
SORIN SLATER (JR)	880359	Pilatus Porter	26	18	12.0	56.0	0	28	38	36	38.00	94.00	4
PAUL GRABSKI	344853	Lincoln Beachey	20	18	10.0	48.0	5	23	23	26	26.00	79.00	5
GREG THOMAS	185281	0:00:00	30	20	12.5	62.5	10	0	0	0	0.00	72.50	6
VICTOR GAGLIANO	110081												
KENNETH JOHNSON	28705												

HLG

Name	AMA #	Flight 1	Flight 2	Flight 3	Flight 4	Flight 5	Flight 6	Flight 7	Flight 8	Flight 9	Best	2nd Best	Total	Place
STAN BUDDENBOHM	189385	77.9	73.2	83.9	86.0	57.0	78.8	86.2	83.6		86.2	86.0	172.2	1
JOHN YOST	906929	30.6	40.8	12.0	48.0	21.0	10.1	3.2	11.9	54.0	54.0	48.0	102.0	2
#REF!	#REF!												DNF	
VICTOR GAGLIANO	110081	50.0	46.6	47.5							50.0	47.5	97.5	3
DENNIS TYSON	137300	27.1	30.7	32.4	38.5	39.2	31.0				39.2	38.5	77.7	4
ROBERT EBERLE	411592	29.5	11.6	31.7	34.0	42.2	32.9				42.2	34.0	76.2	5
PARKER TYSON (Jr)	802447	14.2	16.3	18.5	17.1	21.8	21.9				21.9	21.8	43.7	6
BRANDON KAGAN (Jr)	928289												DNF	
#REF!	#REF!												DNF	
JIM MAYES	28485												DNF	
ROBERT ROMASH	130061												DNF	

NoCal

Name	AMA #	Aircraft	Flight 1	Flight 2	Flight 3	Flight 4	Flight 5	Best	Place
LARRY LOUCKA	1210	Hosler Fury	6:30					6:30	1
WALTER COLLINS	249365	Chambermaid	3:51	4:24	4:44	5:10	5:09	5:10	2
H DIEBOLT	5286	Hosler Fury	3:11	4:09	3:25	4:20	4:21	4:21	3
ROALD TWEET	68634	Piper Sky Cycle	0:58	1:56	1:58	2:02	2:03	2:03	4
ROBERT BOYD	44454	D. H. Beaver	1:50	1:58	1:12		1:58	5	
DEL OGREN	6874	Cessna CR-3	1:55	1:10	1:06		1:55	6	
WILLIAM ODELL	408354		1:14	1:12	1:33		1:33	7	
WILLIAM LYONS	864154	Monocoupe	0:25				0:25	8	
ABRAM VANDOVER	894						DNF		
PAUL GRABSKI	344853						DNF		
ROBERT WARMANN	187						DNF		

WWI ML

Name	AMA #	Aircraft	Down	Place
LARRY LOUCKA	1210		2	1
TIM LAVENDER	269765		1	2

WWII ML

Name	AMA #	Aircraft	Down	Place
LARRY LOUCKA	1210			
SORIN SLATER (JR)	880359			
KENNETH ANDERSON	587497			



## HLS

Name	AMA #	Flight 1	Flight 2	Flight 3	Flight 4	Flight 5	Best	Place
RAYMOND HARLAN	131	36:10					36:10	1
JAMES RICHMOND	4936	27:55	28:01				28:01	2
JEFFREY HOOD	824593	26:50	6:26				26:50	3
DENNIS TYSON	137300	15:08	16:03				16:03	4
BENJAMIN SAKS	663661						DNF	
PARKER TYSON (Jr)	802447						DNF	
LARRY LOUCKA	1210						DNF	

## Dime Scale

Name	AMA #	Aircraft	Bonus	1st Flight	2nd Flight	3rd Flight	Score	Place
DIEBOLT	5286	B.A.T. Monoplane		120	120	120	360	1
OBERT WARMANN	187	Arado		108	108	94	310	2
ATIE BOSMAN	336184	Stinson		50	61	59	170	3
IM LAVENDER	269765	Lloyd CV		44	46	59	149	4
GEORGE WHITE	652626	P-6e		50	44	45	139	5
WILLIAM ODELL	408354	Cessna		38	42	44	124	6
WALD TWEET	68634	S.E.5		24	32	33	89	7
WILLIAM LYONS	864154	B.A.T. Monoplane						
RAYMOND HARLAN	131							
PAUL GRABSKI	344853							

## A-ROG

Name	AMA #	Flight 1	Flight 2	Flight 3	Flight 4	Flight 5	Best	Place
LARRY LOUCKA	1210	13:42					13:42	1
WALD DIEBOLT	5286	10:40					10:40	2
RAYMOND HARLAN	131						DNF	
DAVID ERBACH	198						DNF	
CARL BAKAY	478659						DNF	

## Int Stick

Name	AMA #	Flight 1	Flight 2	Flight 3	Flight 4	Flight 5	Best	Place
TOM SOVA	473169	31:53	34:03				34:03	1
LARRY LOUCKA	1210	29:50	32:32				32:32	2
RAYMOND HARLAN	131	28:17					28:17	3
JEFFREY HOOD	824593	19:16					19:16	4

## 35cm

Name	AMA #	Flight 1	Flight 2	Flight 3	Flight 4	Flight 5	Best	Place
RAYMOND HARLAN	131	24:19	26:30	27:45			27:45	1
TOM SOVA	473169	26:57					26:57	2
NICHOLAS RAY	770974	25:26	25:02				25:26	3
THOMAS IACOBELLIS	6698	22:27					22:27	4
WALTER COLLINS	249365	20:32	19:54	5:48	18:03	15:01	20:32	5

## Manhattan

Name	AMA #	Flight 1	Flight 2	Flight 3	Flight 4	Flight 5	Best	Place
EMIL SCHUTZEL	508384	9:12	11:37				11:37	1
LARRY LOUCKA	1210	7:22	9:02				9:02	2
DAVID ERBACH	198	4:27	6:07	6:36			6:36	3

# FINAL RESULTS FOR THE 2010 INTERNATIONAL POSTAL MINISTICK AND A-6 CONTEST

At long last we have the results for another successful International Ministick and A-6 Postal Contest. Because of previous commitments, the USA Indoor Nationals for one, I have been behind the power curve and for this I apologize. I do have the awards and they will follow this notice in a day or two. We had some close competition this year and we like that. Once again Akihiro Danjo and his band of merry modelers gave us a lesson on how to win, practice, practice, practice. The Brainbuster group and others promise to do better next year. With that notice we will announce now that the Brainbusters will run the 2011 contest, clubs and individuals can expect to receive flyers in October or November. This will give all ample time to prepare for 1 January 2011

Below are the various event winners and all who participated. We wish to thank all and wish everyone good luck in 2011.

## OVERALL CHAMPION

AKIHIRO DANJO JAPAN

## MINISTICK INTERNATIONAL CLASS.

FIRST PLACE	AKIHIRO DANJO	JAPAN
SECOND PLACE	TORU ONISHI	JAPAN
THIRD PLACE	SYOJI KANEKO	JAPAN

## MINISTICK USA CLASS

FIRST PLACE	WALT COLLINS
SECOND PLACE	ANDREW TAGLIAFICO
THIRD PLACE	ED BERRY

## COMBINED A-6 CLASS

FIRST PLACE	AKIHIRO DANJO	JAPAN
SECOND PLACE	TEM JOHNSON	USA
THIRD PLACE	ANDREW TAGLIAFICO	USA

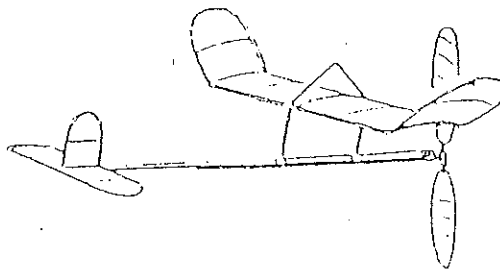

On the reverse page are names, scores countries and other pertinent data on all contestants.

## 2010 INTERNATIONAL POSTAL MINISTICK RESULTS AND SCORES

NAME	FLT SCORE (SEC)	CEILING HEIGHT	CLUB	DATE	
Danjo, Akihiro	691	29.52 ft	K.I.P.C.	20 Mar 2010	1,039.2
Collins, Walt	481	7.75 ft	Brainbusters	27 Mar 2010	1,022.3
Onishi, Toru	653	29.52 ft	K.I.P.C.	20 Mar 2010	982.0
Kaneko, Syoji	520	29.52 ft	K.I.P.C.	20 Mar 2010	782.0
Okayasu, Hiroyuki	514	29.52 ft	K.I.P.C.	20 Mar 2010	773.0
Fujita, Shigeru	510	29.52 ft	K.I.P.C.	20 Mar 2010	767.0
Tagliafico, Andrew	420	21.00 ft	Williamette Modlrs	28 Feb 2010	697.1
Kato, Yoichi	441	29.52 ft	K.I.P.C.	20 Mar 2010	663.2
Kobukai, Syoetsu	424	29.52 ft	K.I.P.C.	20 Mar 2010	637.7
Yaginuma, Tokurirc	414	29.52 ft	K.I.P.C.	20 Mar 2010	622.6
Miura, Shinsuke	400	29.52 ft	K.I.P.C.	20 Mar 2010	601.6
Tida, Miniru	397	29.52 ft	K.I.P.C.	20 Mar 2010	597.0
Berray, Ed	387	36.00 ft	Williamette Modlrs	9 Jan 2010	547.7
Singer, Len	242	7.75 ft	Brainbusters	17 Mar 2010	514.3
Wilson, Roy	260	13.75 FT	BMFA	11 Mar 2010	482.9
Long, Bill	286	23.00 ft	Christ church MAC	28 Mar 2010	467.5
Yamada, Minoru	289	29.52 ft	K.I.P.C.	20 Mar 2010	434.6
Hayashi, Osamu	271	29.52 ft	K.I.P.C.	20 Mar 2010	407.6
Shimizu, Takayuki	258	29.52 ft	K.I.P.C.	20 Mar 2010	388.0
Van Dover	182	7.75 ft	Brainbusters	27 Mar 2010	386.8
Beaton, Aubrey	242	25.00 ft	Scotia Free Flight	14 Mar 2010	382.2
Boudon, Keenan	260	36.00 ft	Williamette Modlrs	9 Jan 2010	368.0
Borland, Chris	256	36.00 ft	Williamette Modlrs	9 Jan 2010	362.3
Boudon, Nathan	175	36.00 ft	Williamette Modlrs	28 Feb 2010	247.7

## 2010 INTERNATIONAL POSTAL A-6 RESULTS AND SCORES.

NAME	FLT. SCORE (SEC)	CEILING HEIGHT	CLUB	DATE	COR. TIME
Danjo, Akihiro	466	42.16 ft	K.I.P.C.	5 Mar 2010	466.00
Johnson, Tem	385	26.50 ft	H.A.F.F.A.	27 Mar 2010	395.50
Taglifico, Andrew	372	36.00 ft	Williamette Modlrs	28 Feb 2010	376.12
Altig, Mike	368	36.00 ft	Williamette Modlrs	9 Jan 2010	372.12
Berray, Ed	329	36.00 ft	Williamette Modlrs	30 Jan 2010	333.12
Wannop, Urlan	313	25.00 ft	Scotia Free Flight	14 Mar 2010	324.49
Beaton, Aubrey	297	25.00 ft	Scotia Free Flight	14 Mar 2010	311.49
Collins, Walt	286	7.75 ft	Brainbusters	27 Feb 2010	309.05
Long, Kay	220	23	Christchurch MAC	28 Mar 2010	232.77
Gilbert, George	220	36.00 ft	Williamette Modlrs	30 Jan 2010	224.12
Alderson, James	218	36.00 ft	Williamette Modlrs	28 Feb 2010	222.12
Singer, Len	189	7.75 ft	Brainbusters	17 Mar 2010	213.05
Long, Bill	193	23.00 ft	Christchurch MAC	28 Mar 2010	205.77
Plassman, Jerry	173	7.75 ft	Brainbusters	27 Feb 2010	196.05
Borland, Chris	186	36.00 ft	Williamette Modlrs	9 Jan 2010	190.12
Boudon, Keenan	138	36.00 ft	Williamette Modlrs	28 Feb 2010	142.12
Kershner, Dave	117	7.75 ft	Brainbusters	27 Mar 2010	140.05
Van Dover, Abram	116	7.75 ft	Brainbusters	27 Mar 2010	139.05
Tate, John	69	7.75 ft	Brainbusters	27 Mar 2010	92.05

ABBREVIATIONS: K.I.P.C. = KANAGAWA INDOOR PLANE CLUB  
H.A.F.F.A. = HEART OF AMERICA FREE FLIGHT ASSOCIATION  
B.M.F.A. = BRITISH MODEL FLYING ASSOCIATION



# INDOOR CAT. GLIDER for 30'X60' TUNNEL FLYING

- Slight Philips entry on wing (less than 1/64")
- Do NOT use excessive pressure when sanding wing Airfoil.
- I trim my models to fly right power + right glide pattern due to flying site restrictions.
- Target weight is 5 grams or less
- I use aliphatic resin for all glue joints.
- No dope for Langley Tunnel flying.
- Start with CG @ 50% of wing chord
- IF model hand glides OK BUT Dives in on recovery from launch then CG. is probably too FAR back.
- USE 1/8" TAN rubber for CATAPULT
- Tweak slight wash-out in TIPS

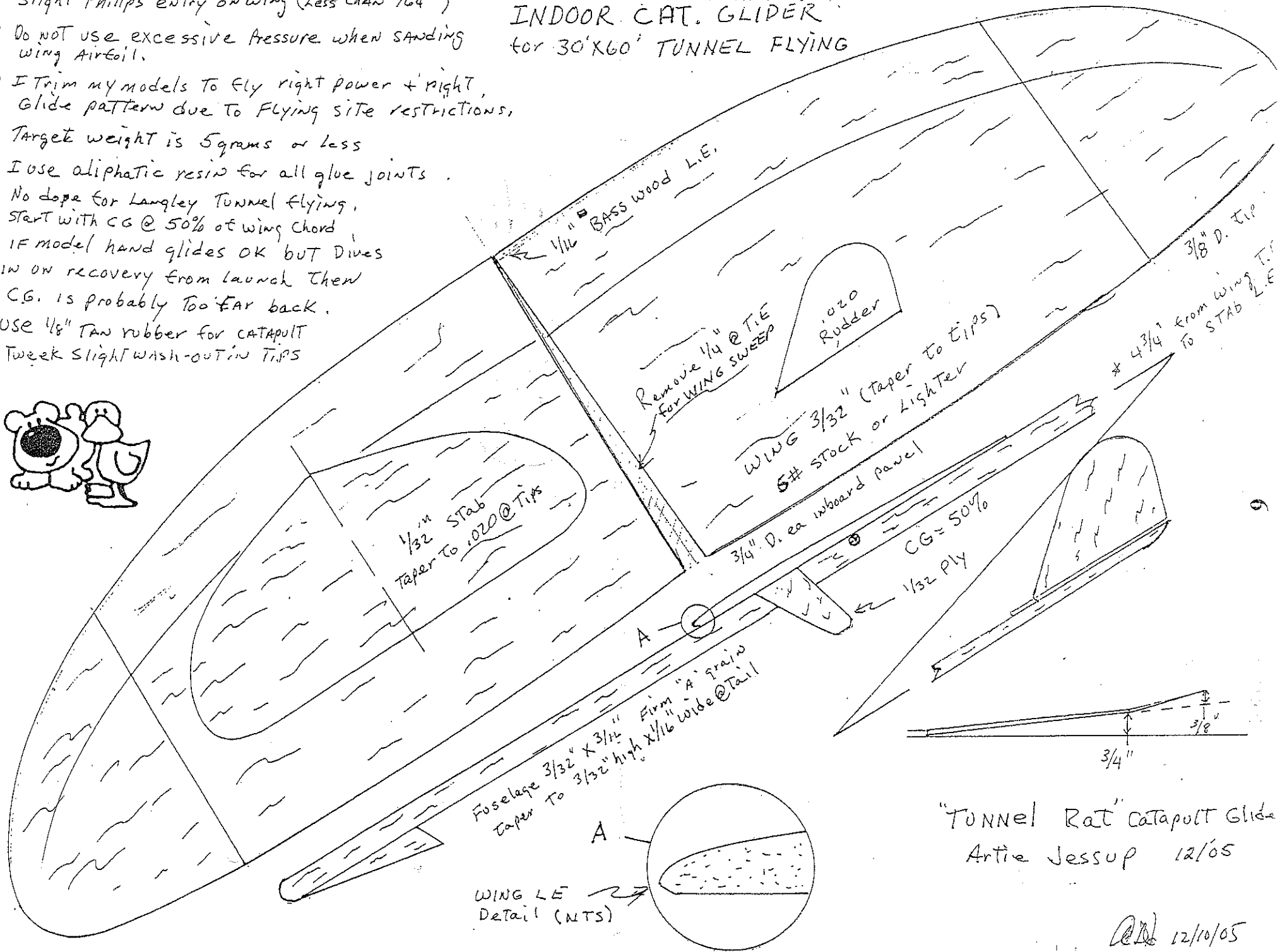
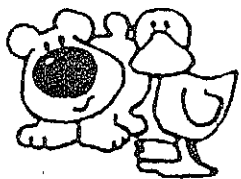

"TUNNEL Rat" catapult Glider  
Artie Jessup 12/05

Artie 12/10/05

# INDOOR

NEWS and VIEWS

ABRAM VAN DOVER, EDITOR  
112 TILLERSON DR  
NEWPORT NEWS, VA  
23602-4011

ISSUE 124  
SUMMER 2010

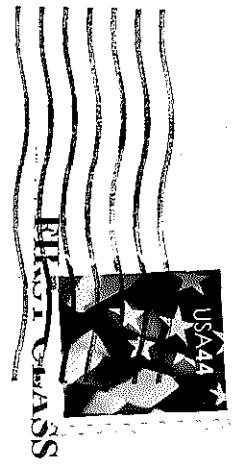
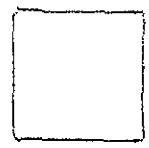

## INAV

Indoor News and Views

Yes!  
Sign me up for \_\_\_ 1 year @ \$15.00 U.S., \$19.00 Canada  
\_\_\_ 2 years @ \$30.00 U.S., \$38.00 Canada  
\_\_\_ Archive CD @ \$45.00 U.S., \$3.00 Shipping

Name \_\_\_\_\_

Address \_\_\_\_\_

City \_\_\_\_\_ State \_\_\_\_\_ Zip \_\_\_\_\_

Send a Sample Copy to a Friend???

Friend's Name \_\_\_\_\_

Address \_\_\_\_\_

City \_\_\_\_\_ State \_\_\_\_\_ Zip \_\_\_\_\_

Send all dues to: Abram Van Dover  
112 Tillerson Dr  
Newport News, VA  
23602